



R-16

4 OUTPUTS. PROFESSIONAL AUTOMATISM for NATIVITY SCENE.

The R-16 module is an automatism, which allows to automatically and cyclically generate "Daybreak, Day, Nightfall and Night", with independent times adjustment for Daybreak-Nightfall as well as for Day-Night. It has two outputs for Daybreak-Day and Nightfall-Night effects.

It also has two independent outputs that will be activated after the day or the night

TECHNICAL CHARACTERISTICS.

Voltage	230 V. C.A.
Minimum Consumption	0.2 mA.
Maximum Consumption	100 mA.
Minimum Output Load	50 W.
Maximum Output Load	500 W.
Effects Timing	From 1 till 120 sec. / From 1 till 120 min.
Protection Fuse	6 A.
Sizes	118 x 101 x 25 mm.

OPERATING MODE.

POWER SUPPLY. The Circuit R-16 has to be supplied by 230 VAC. Using an adequate plug and a cable for mains connect this last one to the input terminal 230 VAC. Install a fuse and a switch as it is indicated in General Wiring Map (see hereafter). Both are necessary to protect the module and for your own security, as it is indicated in EEC regulations. Then, verify that you have correctly connected the module.

Before to connect the module to the mains inserting voltage, please do the rest of connections specified hereafter. Do not forget that in several part of the module there is voltage (230 VAC), for this reason we suggest you to be careful.

Note. Connections indicated as 230 VAC in the wiring map have to be connected to 110 VAC. in Americans countries. Cebek's Modules and/or transformers will be supplied with corresponding modifications for their connection in these countries.

OUTPUTS CONNECTION. LOAD. The module accepts resistive loads like lamp, resistors, etc... DO never connect at the output inductive loads like transformers, neon, Halogen lamp with transformer, etc... The minimum load per output is 50 W., if you connect an inferior load the module doesn't operate correctly. Also, the maximum load per output is 500 W., do never over pass this load to avoid to damage the circuit.

To connect outputs, you have to connect lamps or load that you wish to apply to the terminals indicated in the "General Wiring Map" paragraph. Then, install a 2A. rapid fuse at each output.

OPERATING MODE. The R-16 module allows to automatically and cyclically generate the natural cycle of a Day, dividing this cycle in four effects : Daybreak, Day, Nightfall and Night. The module has four outputs: Day Output & Night Output, Auxiliary output Day, Auxiliary output Night.

DRAWING OF THE R-16 OPERATING CYCLE AND OUTPUTS STATE

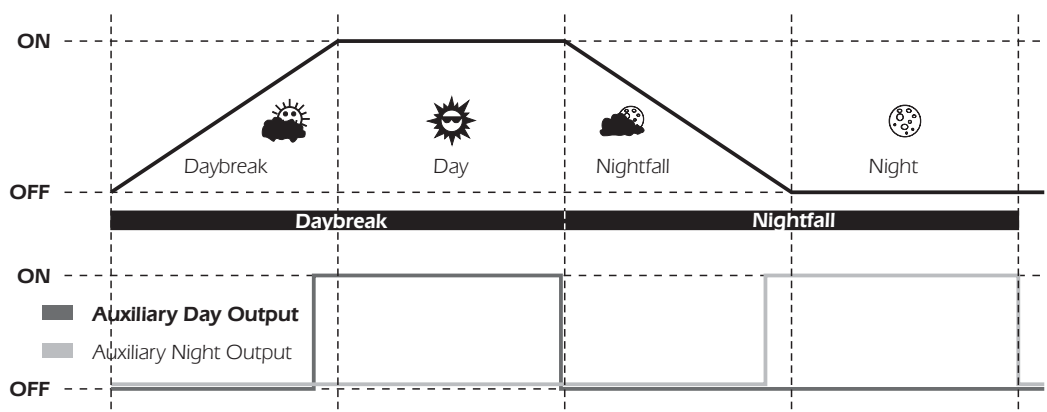



OPERATING MODE.

Day Output. This output identified on the PCB as OUT A, is charged to automatically generate "Daybreak and Day" effects.

When the day cycle is on Daybreak effect, the OUT A output will start to progressively light according to the time adjustment speed. (see hereafter). The effect will finish with the total and maximum output light.

After, the day cycle will continue with the Day effect. During this effect, and till it finish the output will be completely lighted. This effect duration will depend on adjusted time.

OUTPUTS STATE DURING THE DAYBREAK EFFECT

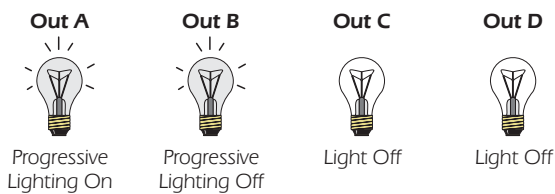

OUTPUTS STATE DURING THE DAY EFFECT

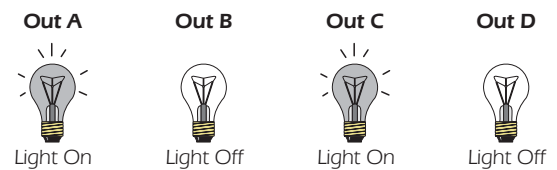

Night Output. After Daybreak and Day effects, the day cycle will continue with the Nightfall. At this moment, the Day Output (OUT A) will be progressively disconnected and the Night Output indicated on the PCB as OUT B takes over.

The Nightfall will start the progressive lighting of this output (OUT B) till reach, according to the previously adjusted time, at the maximum (total lighting). At this moment, the module will continue the day cycle with the Night effect, maintaining the output completely connected till it finishes.

After the night, the R-16 module will start again all the process, from the daybreak. The virtual simulation of a day cycle will repeated till you disconnect the R-16 module.

Auxiliary Day Output. Identified on the PCB as OUT C, its function as Auxiliary Day Output is simple. Few seconds before to start the Day effect, this output will be activated and maintained connected during the Day effect. When this one will be finished, the Auxiliary Day Output (OUT C) is disconnected.

OUTPUTS STATE DURING THE DAYBREAK EFFECT

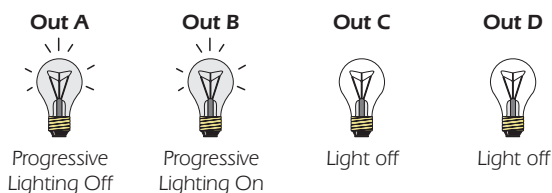

OUTPUTS STATE DURING THE NIGHT EFFECT

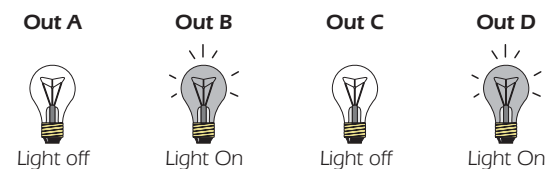

Auxiliary Night Output. The Auxiliary Night Output identified on the PCB as OUT D, will be connected few seconds before to start the Night effect, this output will be activated and maintained connected during the Night effect. When this one will be finished, the Auxiliary Night Output (OUT D) is disconnected.

EFFECTS TIMING ADJUSTMENTS. As we have indicated you previously, the R-16 module divide a virtual day in four main effects : Daybreak, Day, Nightfall and Night. The effects timing adjustment could be adjusted optimising then the day representation according to the end-user's wish. The adjustment is done thanks to two potentiometers inserted on the PCB. See "General Wiring Map" paragraph. The potentiometer referenced as "Rampas" will adjust the time of Daybreak and Nightfall effects, assigning the same time for both.

The "Day/Night" will adjust Day and Night effects, assigning the same time for both.

There are two time scales that you could apply for these potentiometers: Seconds or Minutes. The R-16 module offers a battery composed by two switches referenced as "times". Each switch will control the time scale for Daybreak / Nightfall effects (switch 1) and Day / Night (switch 2). If you wish to operate in minutes scale and that potentiometers adjust between 1 and 120 minutes, you have to place the corresponding switch in ON position,

At the opposite case, if you wish to operate in seconds scale and that potentiometers adjust between 1 and 120 seconds, you have to place the corresponding switch in OFF position,



R-16

4 OUTPUTS. PROFESSIONAL AUTOMATISM for NATIVITY SCENE.

OPERATING MODE.

R-16'S STARTING. Before to supply the module to allow it to operate, you have to be sure that all required connections have been done.

The module's starting could be configured to start its cycle from any of the four available effects which divide the day : Daybreak, Day, Nightfall, Night. For this function, the circuit has a battery composed by two switches and identified as "START". According to the position of these two switches (ON or OFF), the R-16 module will start its operating mode on a determinate effect.

See the information hereafter and configure the "START" battery according to your needs.

TO CONFIGURE OPERATING TIMES SCALE.

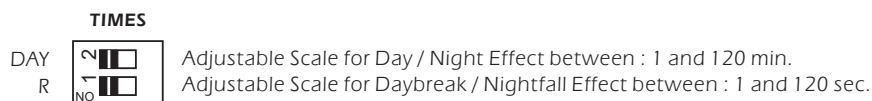
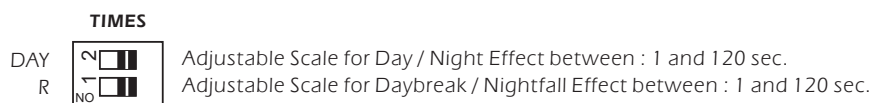

DO NOT FORGET. Hereafter we remember you several necessary notes to obtain a correct and optimal module's operating mode.

You have to protect the module against contact with metallic parts and/or the union of its own heatsinks. Don't change the fuse if the power supply is connected and install a switch as it is indicated on the "General Wiring map".

Adjust the timing thanks to a plastic screwdriver and avoid doing this operation with the power supply connected. Don't forget that 230 V are circulating through the circuit and that different metallic parts of it are under voltage.

Switch 1	Switch 2	Effect Start:
OFF	OFF	Daybreak
OFF	ON	Nightfall
ON	ON	Night
ON	OFF	Day

Install the circuit into a plastic enclosure, properly ventilated or into any other system allowing to dissipate the produced heat during the circuit operating.

Adjustment potentiometers, even if they are linear and because of their own nature, don't never respect an operating mode completely linear. For this reason, when you will adjust them, it is possible to note some sudden jumps according to the potentiometer turns. If you wish a higher sensitivity, you have to substitute supplied potentiometers by others with the same value but "multi-round" type.



LIGHT REGULATORS.

Rev. 9852

R-16

GENERAL WIRING MAP.

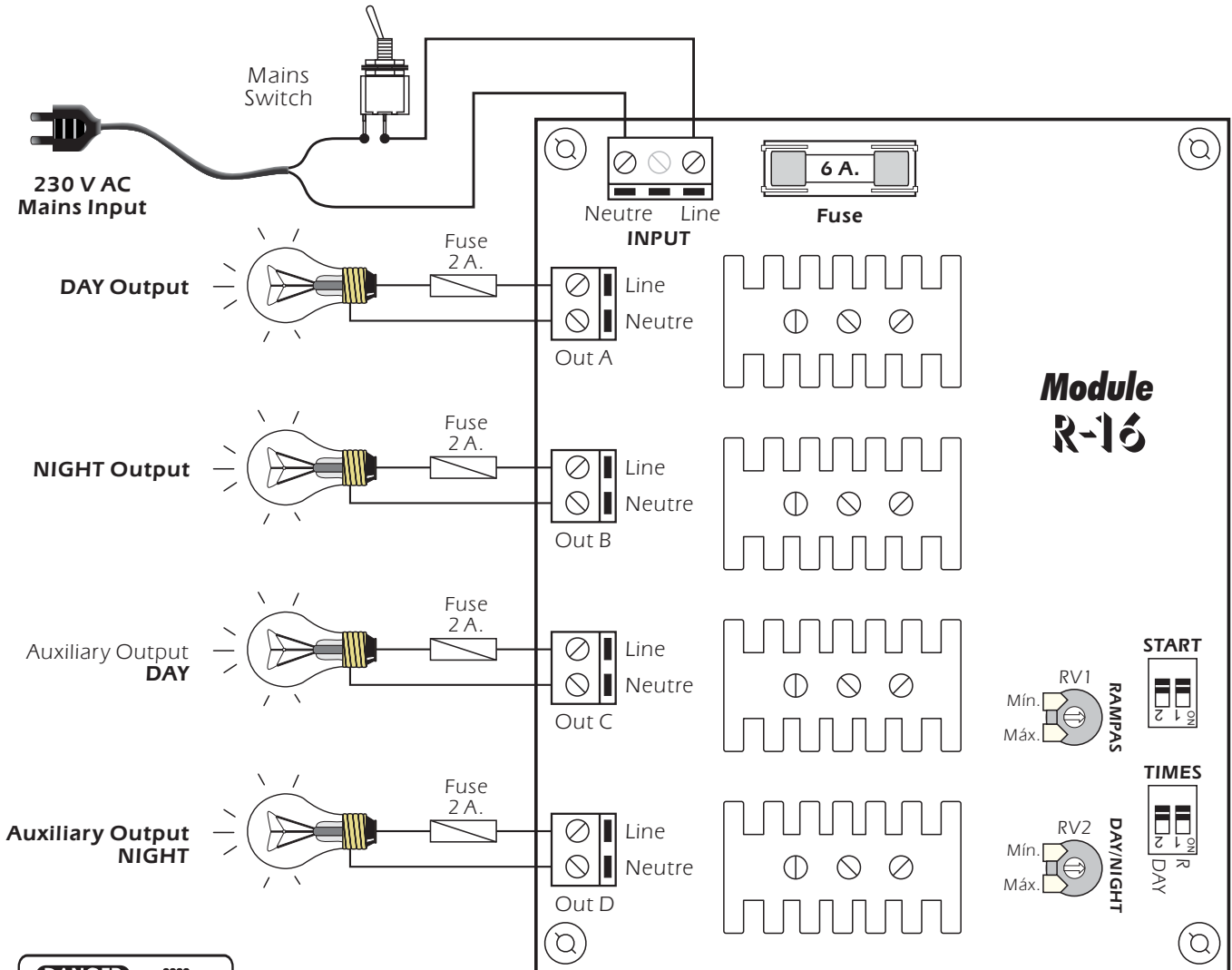

TECHNICAL CONSULTATIONS.

If you have any doubt, you could contact your wholesaler or our Technical Department.

- E-Mail, sat@cebek.com | Fax. 34.93.432.29.95 | by mail. P.O. Box. 23455 - 08080 Barcelona - Spain.

- **Keep the invoice of this module.** For any repair, the corresponding invoice had to be added. If the invoice is not presented together with this module, the module's warranty will be automatically cancelled.

All the module's CEBEK have **3 years of total warranty** in technical repairing, and spaces from the date of buy.

Much more CEBEK module's are available in our products range, please, require our general catalogue or visit our Web side: [Http://www.cebek.com](http://www.cebek.com)

MORE ! **CEBEK's**

GARANTIE **GARANTIA**
3 **AÑOS**
ANNÉE **TO**
YEARS **TAL**
WARRANTY **ANY**