

Regulators of activation ramp (from 0 to 100 %) or extinction ramp (100 % to 0), with selection through witch input.

The ramp during ramp and maintenance in On/Off position can be independently configured with different timing for a more or less long effect.

They do not admit inductive loads as PL lamps PL, neon, fluorescent, etc.

The R-511 model is identical to the R-111 model but it includes a base for its installation on a DIN-Rail. Likewise the R-513 module is identical to the R-113 module but incorporating a

TECHNICAL CHARACTERISTICS

Input voltage: 230 V. AC. 10%. (50-60 Hz).

Load adjustment: From 0 to 100%. 230 V.A.C.

Minimum Load: 50 W.

Maximum Load: (R-111/511 = 750 W.), (R-113/513 = 1500 W.).

Operating indication: Led 5 mm.

Input fuse: (R-111/511 = 4 A.), (R-113/R-513 = 8 A.).

Control input: Contacts closure by signal without power.

Ramp timing adjustment: Variable Resistor and scale dyps. (1-120 sec. / 1-120 min.).

Operating temperature: -25 °C up to +55 °C.

230 V Input/Output. Maximum section of wire: 2,5 mm.

Net weight: (R-111 = 90 gr.), (R-511 = 135 gr.), (R-113 = 110 gr.), (R-513 = 160 gr.).

Length x Width: (R-111/R-113 = 98,75 x 72 mm.), (R-511/R-513 = 101,2 x 77,5 mm.).

Height: (R-111/R-511 = 35 mm.), (R-113/R-513 = 45 mm.).

Rules: 89/336/CEE Electromagnetic Compatibility and its 32/31/CEE and 93/68/CEE modifications. RoHS free.

INSTALLATION

Input and Output.

To be in accordance with the CE norm you have to install an additional switch before the module's supply, as it is indicated in General Wiring Map (see hereafter). Both are necessary to protect the module and for your own security,

As concern the section of the input power supply cable as well as the switch, they have to be selected according to the consumption / power that the device will control.

Before to connect the module to the mains inserting voltage, please do the rest of connections specified hereafter. Do not forget that in several part of the module there is voltage (230 VAC), for this reason we suggest you to be careful during the handling and assembling.

In the output, the device or load to control will have a minimum consumption of 50 W. and a maximum not superior to the specified one in the technical characteristics for each model. Do not use inductive load as PL lamps, or fluorescent, etc... and it have to be connected according to the indications of line "L" and neutral "N".

Control and Reset.

Inputs to select the wished effect or to do a reset are done by closing contacts. To do this connection you have to use contacts without potential, without tension, as a switch, a relay, etc.

The selection of the "daybreak - day" effect is established connecting the "Day" input with the "Com." terminal. The effect "night fall - night" is established connecting the "Night" input with "Com." terminal. The Reset is done closing the both terminals of the "Reset" input.

The length of the cable for control input or for the reset have to be as short as possible. If the distance is superior to 50 cm it will be necessary to use shielded cable, connecting the braid to the terminal with the ground symbol, or to the "Com." terminal, as correspond. In any case the maximum total length has to be inferior to 2 m.

PCB Fuse.

The module includes an input protection fuse. To substitute the fuse, you have to previously disconnect the 230 V input. Then, removing the protector you could substitute the fuse by a new one with the same original value. Do never use fuses with different value from the specified one in each model.

Do not forget.

The module must not be installed in places with great dampness, very high temperatures, or with possibility to be in contact with liquids.

The installation has to be preferably done into in a box, enclosure or rack suitably ventilated.

You have to avoid contact between the circuit and metallic objects like bracelets, chains, etc....

You can activate the module, once the installation has been completed. The Led will light on to indicate the operating state of the circuit. If the module is disconnected or if a problem is detected, the led will light off.

Considerations in the installation.

OPERATING MODE

Configuration of the dip.

The circuit allows different configurations of the operating mode and timing scales according to the dyps' position, incorporated on the board. See the Fog.1

Fig. 1. Configuration of the dip.

- To assign the operating mode and timing to the circuit

		On	Off
SW1	Ramps Timing	minutes	seconds
SW2	Solids Timing	minutes	seconds
SW3	SW4		
Off	Off	Night starting	
Off	On	Daybreak starting	
On	Off	Day starting	
On	On	Night fall starting	

Dip. 1. Time scale for effect Ramp, (Daybreak and Night fall). It assigns to the timing adjustment resistor of the ramp a stroke in seconds or minutes.

Dip. 2. Time scale for Solid effect, (Day and Night). It assigns to the timing adjustment resistor of the solid a stroke in seconds or minutes.

Dip. 3 and Dip 4. It configures the starting point of the device when the supply is activated (day, night fall, night, daybreak)

Note. In order to allow the circuit to take in account any modification done on the dip, it will be necessary to deactivate and then to reactivate the power supply

OPERATING MODE

Effect selection, starting point and timing.

There are two concepts that must be contemplated to understand the module's operating mode, the operating starting and the operating effect selection.

The selection of the effect remains established when you activate Day or Night input, as it is indicated in the Installation, connecting Com input. There is always to have a Day or Night input connected to Com., and to never connect to the same, the three inputs, otherwise the circuit would not be able to recognize the selected effect.

The operating starting is the point from which the module starts when the power supply is activated. This one can be different from the selected effect, and remains established according to the selected combination through dyps 3 and 4.

The module really contemplates the operating cycle in four points: night, daybreak, day and night. To establish the operating starting in any of these point implies that the module will start from this one up to reach the selected effect in the input.

For instance, we established that the module will start from the daybreak and the operating effect is the night. Firstly there will appear the progressive starting ramp, followed by the day period and then the whole night effect, the night fall, to be finally switched off, (night).

The same example, but this time establishing the starting on the day, with the same input selection for an operating effect in night. The module will not need to complete any previous step and it automatically will initiate the ramp of night fall to finish in switch off, (night).

The time required by the circuit to complete each ramp, as well as the time required to maintain a solid state, (day or night), to reach the selected effect on the input, is established adjusting "Ramps" or "Solid" variable resistors on the wished point. The resistors' margin is established between a minimum of 1 and a maximum of 120. To selected between second or minutes mode, you have to combine dyps 1 and 2.

How does effect finish?

When the operating effect selected in the circuit is completed, the circuit is maintained in this last state.

If you switch inputs contacts, you will do the opposite effect, without taking in account the starting point.

If you do a Reset or Re-feed on the circuit, it will start the operating from the starting point.

WIRING MAP R-111 / R-511 / R-113 / R-513

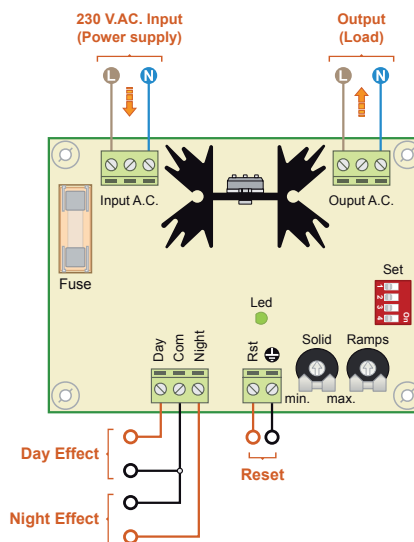

WARRANTY and TECHNICAL INCIDENCES

Warranty.

All cebek modules have a total warranty of 3 years as concern components and labour man. All damage, error or mistake due to problems independent from the circuit, connection, installation or operating mode, as well as wrong handling are not included in this warranty. More over it will be necessary the purchase invoice of this module for any claim.

To contact our technical depart. Please contact: - sat@cebek.com or by fax (+34) 93.432.29.95 or by mail at the following address: FADISEL - c/Quetzal, 17-21 - 08014 Barcelona - SPAIN.

Technical Department.

sat@cebek.com or by fax (+34) 93.432.29.95 or by mail at the following address: FADISEL - c/Quetzal, 17-21 - 08014 Barcelona - SPAIN.

CEBEK offers a Wide and complete modules range which can be of your interest.

Please visit www.cebek.com